



roof top loading made
safe and easy



Approved by major fleet customers

Loading and unloading equipment from the roof of a panel van is a risky business, compounded by winter conditions and unsafe and difficult means of access. Such conditions can lead to injuries and associated claims.

Operators Health and Safety is always a high priority for most businesses as the cost of absenteeism and injury claims rise in proportion to the demands of legislation and the expectations of employees.

Easi-Load was developed in response to consumer demand for a safe, simple and inexpensive means of loading and securing ladders or other equipment onto the roof of, standard, semi-high and high roof commercial vehicles.

Easi-Load significantly reduces the risk of strain and injury caused by loading and unloading.

A number of in-built features aim to satisfy both individuals and the companies needs and demands for a better, healthier and safer way of moving equipment from the ground onto the roof of a vehicle.



top loading

system for light commercial vehicles

Easi-Load

Easi-Load enables items to be loaded and unloaded safely. Consisting of a fixed outer and sliding inner galvanised mild steel carrier, the sliding carrier is unlocked by a special key, which also acts as a pull handle. Once the key is engaged and activated this releases the double locking mechanism and allows the carrier to slide out of the fixed frame, pivot and present itself in an upright position at the rear of the vehicle. Throughout this operation the operator has full control at all times, standing safely behind the vehicle away from other traffic and avoiding pedestrians in the walkway.

Single Ladder Rack

Secure housing of ladders is provided by the Ski assembly which is completely adjustable in the width up to 520mm maximum. Manufactured from galvanised steel the cross rails secure to a sliding carrier, together with one set of aluminium skis, rung locator and securing rope. The ski unit is adjustable as mentioned above in order to accommodate most size of ladders.

Double Ladder Rack

Similar in design and manufacture to the single option the Double Ladder Rack assemblies offer the facility of carrying 2 ladders side by side.

Vehicle Cross Member Kits

Whilst the Easi-Load will suit most manufacturers roof cross members, Bri-Stor have a standard range which are supplied with all necessary feet, brackets and assembly fixings to mount directly onto the vehicle roof.

Two or three bars complete with fixings make up this Cross Member Kit (depending on vehicle sizes). All parts are manufactured from galvanised mild steel. (Unless otherwise specified.)

Ladder Clamps

Ladder clamps offer the operator the option to secure ladders comes complete with padlock.



602-0432

Single Ladder Rack

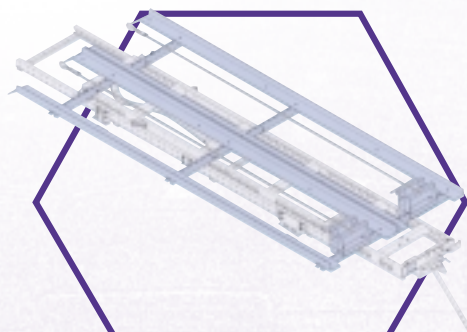

602-0433

Double Ladder Rack

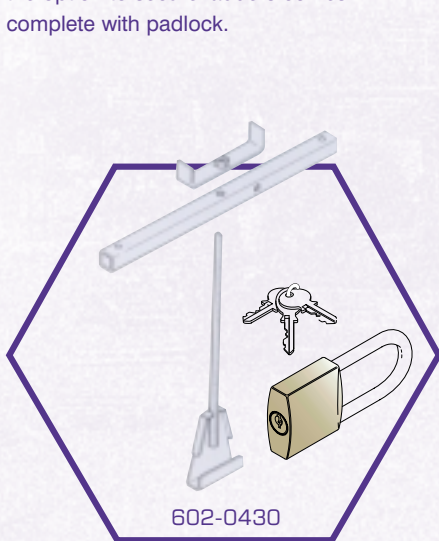

602-0430

Ladder Clamps

(complete with padlock kit)

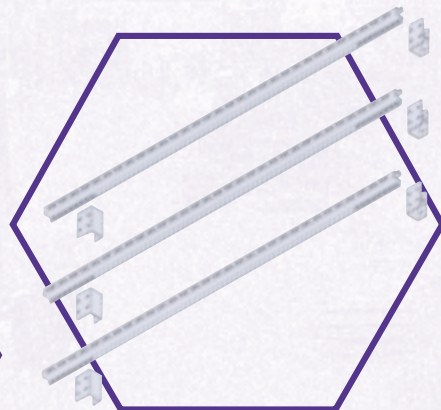

Vehicle Cross Member Kits

(refer to price list for part no.s)



the features

- Significantly reduces risk of strain and injury, which results in lost working time and ultimately associated claims
- Single operator use
- Considers safety-loads at the rear of the vehicle not into pedestrian walkway or vehicle freeway
- Full control of load at all times
- Eliminates requirements for steps, door ladders or roof platforms
- Fits onto most major manufacturers cross members
- Flexibility - available as a single or double ladder rack storage
- Fits standard, semi-high and high roof vehicles

the benefits

- Totally adjustable width on Ski Assemblies
- Loading and unloading of payload at ground level
- Payload capacity 70kg (subject to vehicle manufacturers recommended roof loading capacities)
- Lightweight and durable
- Galvanised and stainless steel components for total corrosion resistance
- Automatic double locking device
- Highly competitive price
- Virtually maintenance free
- Product protected by patent and design rights



Bri-Stor are internationally recognised for their comprehensive range of storage and security systems designed and developed to fit most light commercial vehicles.

For further information please contact the sales team.



Bri-Stor Systems Ltd . Hixon . Staffordshire
 ST18 0PF . Tel 01889 271202 . Fax 01889 271178
 E-mail: easi-load@bri-stor.co.uk Website: www.bri-stor.co.uk

