

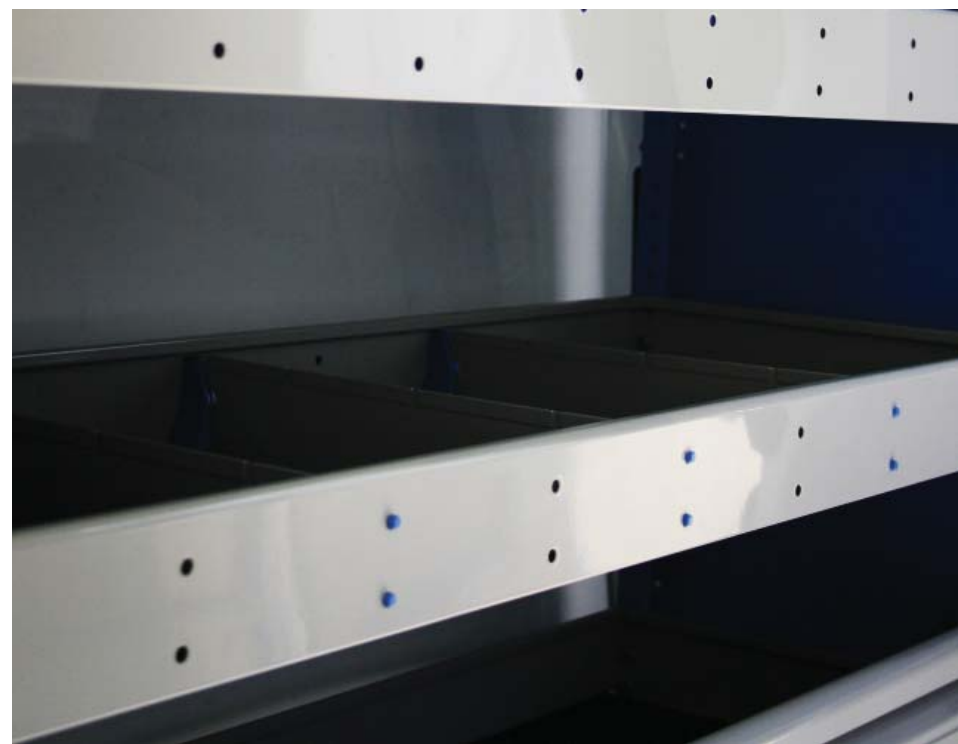

BRI-STOR
systems 

ELITE
PRODUCT CATALOGUE

light commercial vehicle storage systems
vehicle storage systems
storage systems





CONTENTS



Bri-Stor Systems	4
Product Information	6
Catalogue Structure	8
Installation	10
Product Range	
580 width	12
830 width	13
1120 width	14
1620 width	16
Standard Components	
Additional Options	18
Lockers & Stand Alone Modules	19
Shelves	20
End Panels	21
Angles, Trim & Rails	22
Drawers	23
Tool Cases & Dividers	24





Bri-Stor Systems has been established since 1983 and is the leading supplier of vehicle security and storage solutions. We lead the way in providing modular storage systems to individuals and businesses spanning a variety of industries.

The unique approach we adopt to our customers' requirements has given us an invaluable understanding of our industry. Our experience combined with our continued research and investment into optimal manufacturing techniques makes Bri-Stor a highly competitive and quality assured company.



Whether your business operates 1 vehicle or over 50 vehicles, rest assured you will receive exactly the same level of service. We take great pride in our ability to create a solution that suits your daily requirements. Perhaps you need equipment from our standard range or something a little more bespoke? Whatever your business or situation we will always come to the same conclusion, customer satisfaction.



This brochure defines our lightweight and high strength **ELITE** range of storage systems, which are designed to suit all light commercial vehicles.

If you have any enquiries regarding our products or services please contact our sales team on:

+44 (0)1889 271202 or visit our website at **www.bri-stor.co.uk**







DESIGN

We have designed our ELITE range on extensive experience through listening to professionals that use our systems on a daily basis and providing commercial vehicle storage solutions for over 25 years.

QUALITY

Quality assurance is taken very seriously at Bri-Stor and we strive to deliver a flawless service to all our customers, regardless of fleet size. We manufacture our products in the UK, at our own purpose built facility. This gives us complete control over our operations enabling us to guarantee a high quality standard.

We are accredited to the TS16949 Automotive Quality Management System - this means that the products we are offering to you are produced to the same exacting standards of those supplied to automotive manufacturers.

Using a material with a yield strength of almost 4 times that of mild steel, enables component thickness to be significantly reduced. This enables us to maintain integrity in both product strength and durability.

FULLY CRASH TESTED SYSTEM

Safety is not something we take lightly at Bri-Stor. As an advisor to many Transport Associations in the UK we have an important role to play when it comes to safe loading practices.

Fully loaded storage systems have been crash tested in a head on impact test, the systems remained intact within the vehicle load compartment and proved to meet with all safety requirements.

A GREEN SOLUTION

In accordance with our ISO 140001 accreditation a significant amount of our storage system is recyclable.

We see no reason why after 3 or 4 years our system can't be installed into a new vehicle. We are so confident in the quality of our products we will even give you a 3 year product guarantee.

Being able to get a second life out of your investment has less of an impact on the environment.

ULTRA LIGHTWEIGHT CONSTRUCTION

ELITE is a lightweight, fuel saving storage system, which is fast becoming the best choice for cost-conscious fleet operators. Products are manufactured using ultra high strength, lightweight steel because we understand the impact a heavy storage system can have on your business.

The ELITE product range gives weight savings of over 33% compared to existing products. This results in improved fuel consumption and an increase of payload for tools and equipment.

'We get more out so you can get more in'





CATALOGUE STRUCTURE

WIDTHS

The ELITE product range is broken down into four standard unit widths:

580mm



830mm



1120mm

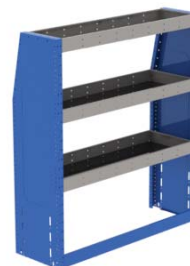

1620mm



These four standard sizes cover the entire range to fit into all of UK light commercial vehicles, and allow you to easily create a flexible system, specific to your trade.

HEIGHTS

950mm high units will have square end panels with the top tray directly on top and due to 950mm height the top shelf on the image shown in the catalogue is lost (only on jerry can storage and drawer/tool case module units).

1250mm & 1625mm high units will have tapered end panels with the top tray located inside.

1250mm product
image shown throughout
catalogue



950mm product
option from image shown

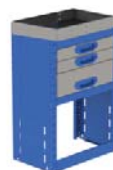

1250mm & 1625mm
High Unit
(showing tapered end
panel and top tray assembly)



950mm High Unit
(showing end panel and
top tray assembly)



WORKTOP OPTION

If the product has the option of a worktop, a text line below the product picture will state * *worktop option available*.

Add 'W' at end of Part No for the worktop option - example: M83-04-AAW

Worktop options are as shown but
950mm units with top shelf substituted for worktop
1250mm & 1625mm with second shelf substituted for worktop

On 950mm units
height will change
to 900mm



JERRY CAN OPTION

Units with 'Jerry Can Storage' have a bracket below the bottom shelf which adjusts to secure the amount to store.

All units are set to have the bottom shelf at 425mm - apart from the 'Jerry Can Storage' units whereby shelves are at 600mm

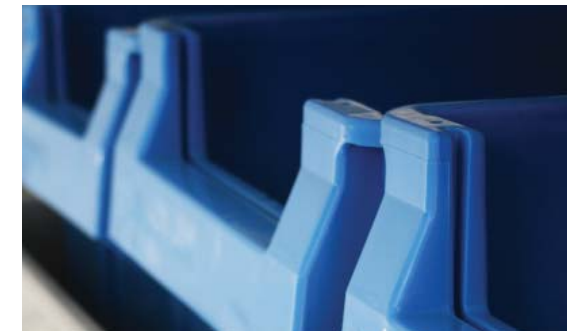

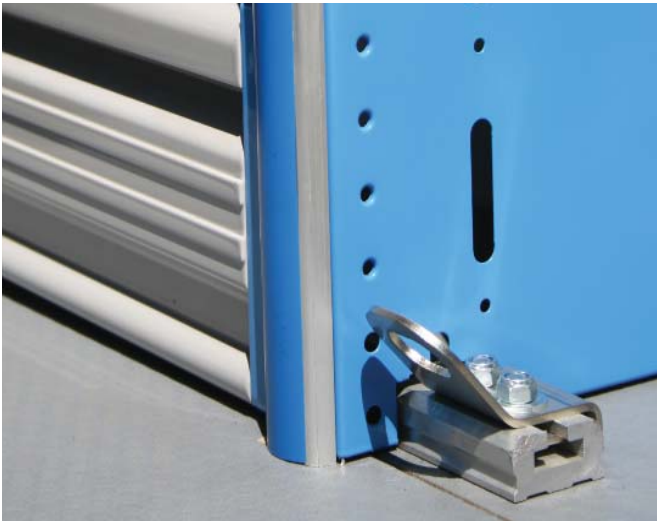

INSTALLATION

A unique safety tested floor rail system ensures a rapid installation.

For installation you will be issued with a floor rail and top fixing bracket. The brackets and floor sections are bespoke to each vehicle and so are not listed in this brochure, for information please call **+44 (0)1889 271202** and one of our sales members will be happy to help you order.

Our flooring systems are manufactured from high grade phenolic plywood and treated with a non-slip texture. This produces a solid base for any storage system, whilst improving functionality and appearance. Furthermore, the use of a single specialist fastening system, requiring only basic tools, has improved installation times dramatically.

Each floor is pre-cut to the exact profile of your vehicle and has been designed to be fitted quickly and simply. The floor is manufactured to fit to the pre-existing fixing points of the vehicle and is supplied in manageable sections - depending on the vehicle wheelbase, floors can require from 2 to 6 sections.



(top fixing bracket to be secured on top of unit to vehicle cant rail)

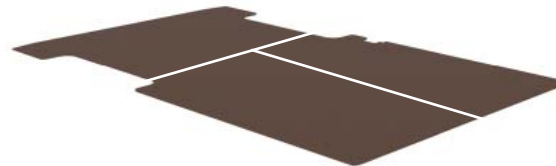

(typical 3 section bri-stor floor)

Please be aware that in some instances of floor designs you may need to screw or glue the floor onto your vehicle along the joins where sections meet.

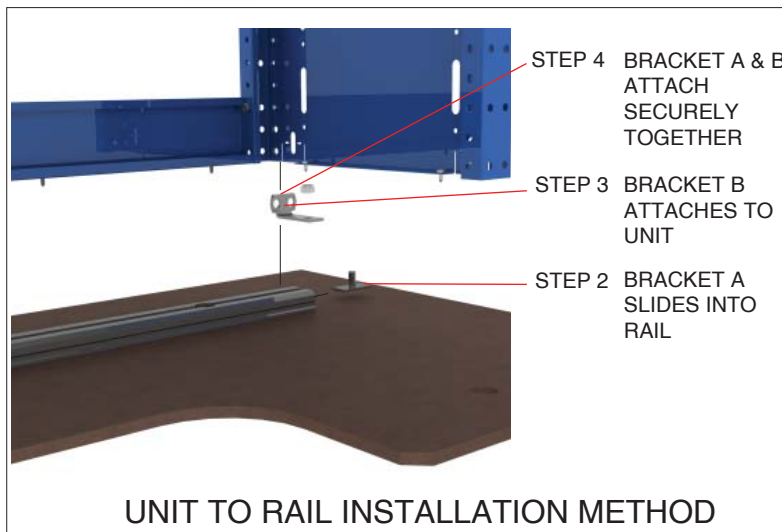
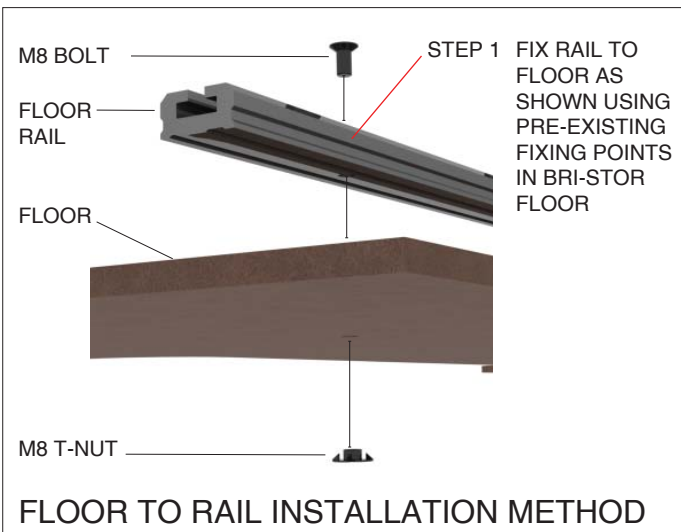

STORAGE MODULES



(1250mm high options shown)



Shelving unit

Part No	H	D
M58-01-AA	950	355
M58-01-AB	1250	355
M58-01-AC	1625	355
M58-01-BA	950	455
M58-01-BB	1250	455
M58-01-BC	1625	455



Shelving unit with dual drop front

Part No	H	D
M58-02-AA	950	355
M58-02-AB	1250	355
M58-02-AC	1625	355
M58-02-BA	950	455
M58-02-BB	1250	455
M58-02-BC	1625	455



Shelving unit with Jerry Can storage

Part No	H	D
M58-03-AA	950	355
M58-03-AB	1250	355
M58-03-AC	1625	355
M58-03-BA	950	455
M58-03-BB	1250	455
M58-03-BC	1625	455



Shelving unit with triple drawer module

Part No	H	D
M58-04-AA	950	355
M58-04-AB	1250	355
M58-04-AC	1625	355
M58-04-BA	950	455
M58-04-BB	1250	455
M58-04-BC	1625	455



Shelving unit with triple tool case module

Part No	H	D
M58-05-AA	950	355
M58-05-AB	1250	355
M58-05-AC	1625	355
M58-05-BA	950	455
M58-05-BB	1250	455
M58-05-BC	1625	455



Shelving unit with cupboard storage

Part No	H	D
M58-06-AA	950	355
M58-06-AB	1250	355
M58-06-AC	1625	355
M58-06-BA	950	455
M58-06-BB	1250	455
M58-06-BC	1625	455

(1250mm high options shown)



Shelving unit

Part No	H	D
M83-01-AA	950	355
M83-01-AB	1250	355
M83-01-AC	1625	355
M83-01-BA	950	455
M83-01-BB	1250	455
M83-01-BC	1625	455



Shelving unit with drop front

Part No	H	D
M83-02-AA	950	355
M83-02-AB	1250	355
M83-02-AC	1625	355
M83-02-BA	950	455
M83-02-BB	1250	455
M83-02-BC	1625	455



Shelving unit with Jerry Can storage

Part No	H	D
M83-03-AA	950	355
M83-03-AB	1250	355
M83-03-AC	1625	355
M83-03-BA	950	455
M83-03-BB	1250	455
M83-03-BC	1625	455



Shelving unit with triple drawer module
 * worktop option available

Part No	H	D
M83-04-AA	950	355
M83-04-AB	1250	355
M83-04-AC	1625	355
M83-04-BA	950	455
M83-04-BB	1250	455
M83-04-BC	1625	455

(1250mm high options shown)



Shelving unit

Part No	H	D
M110-01-AA	950	355
M110-01-AB	1250	355
M110-01-AC	1625	355
M110-01-BA	950	455
M110-01-BB	1250	455
M110-01-BC	1625	455



Shelving unit with drop front

Part No	H	D
M110-02-AA	950	355
M110-02-AB	1250	355
M110-02-AC	1625	355
M110-02-BA	950	455
M110-02-BB	1250	455
M110-02-BC	1625	455



Shelving unit with Jerry Can storage

Part No	H	D
M110-03-AA	950	355
M110-03-AB	1250	355
M110-03-AC	1625	355
M110-03-BA	950	455
M110-03-BB	1250	455
M110-03-BC	1625	455

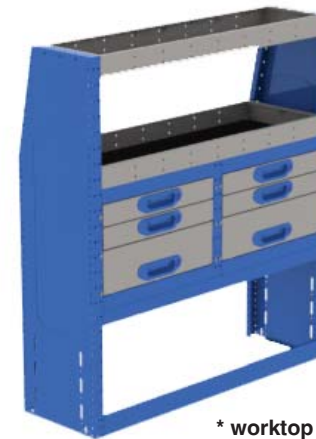

* worktop option available

Shelving unit with triple drawer module

Part No	H	D
M110-04-AA	950	355
M110-04-AB	1250	355
M110-04-AC	1625	355
M110-04-BA	950	455
M110-04-BB	1250	455
M110-04-BC	1625	455



* worktop option available

Shelving unit with triple drawer/cupboard module

Part No	H	D
M110-07-AA	950	355
M110-07-AB	1250	355
M110-07-AC	1625	355
M110-07-BA	950	455
M110-07-BB	1250	455
M110-07-BC	1625	455



* worktop option available

Shelving unit with triple drawer/tool case module

Part No	H	D
M110-08-AA	950	355
M110-08-AB	1250	355
M110-08-AC	1625	355
M110-08-BA	950	455
M110-08-BB	1250	455
M110-08-BC	1625	455



* worktop option available

Shelving unit with triple drawer module

Part No	H	D
M110-09-AA	950	355
M110-09-AB	1250	355
M110-09-AC	1625	355
M110-09-BA	950	455
M110-09-BB	1250	455
M110-09-BC	1625	455



* worktop option available

Shelving unit with drawer/tool case module

Part No	H	D
M110-10-AA	950	355
M110-10-AB	1250	355
M110-10-AC	1625	355
M110-10-BA	950	455
M110-10-BB	1250	455
M110-10-BC	1625	455



(1250mm high options shown)

Shelving unit

Part No	H	D
M160-01-AA	950	355
M160-01-AB	1250	355
M160-01-AC	1625	355
M160-01-BA	950	455
M160-01-BB	1250	455
M160-01-BC	1625	455



Shelving unit with drop front

Part No	H	D
M160-02-AA	950	355
M160-02-AB	1250	355
M160-02-AC	1625	355
M160-02-BA	950	455
M160-02-BB	1250	455
M160-02-BC	1625	455



Shelving unit with Jerry Can storage

Part No	H	D
M160-03-AA	950	355
M160-03-AB	1250	355
M160-03-AC	1625	355
M160-03-BA	950	455
M160-03-BB	1250	455
M160-03-BC	1625	455

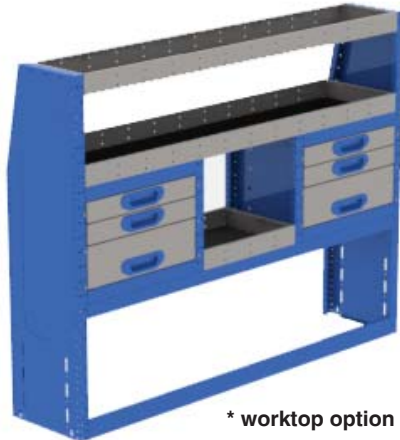

* worktop option available

Shelving unit with drawer/shelf module

Part No	H	D
M160-04-AA	950	355
M160-04-AB	1250	355
M160-04-AC	1625	355
M160-04-BA	950	455
M160-04-BB	1250	455
M160-04-BC	1625	455

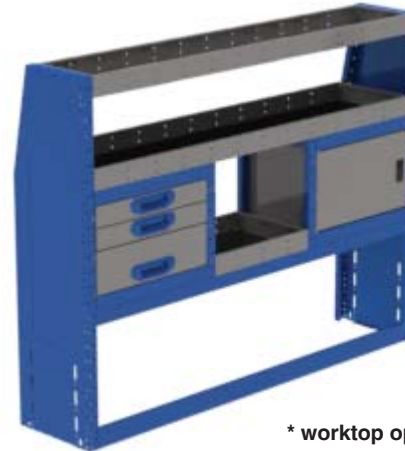

* worktop option available

Shelving unit with drawer/shelf/cupboard module

Part No	H	D
M160-07-AA	950	355
M160-07-AB	1250	355
M160-07-AC	1625	355
M160-07-BA	950	455
M160-07-BB	1250	455
M160-07-BC	1625	455



* worktop option available

Shelving unit with drawer/shelf/tool case module

Part No	H	D
M160-08-AA	950	355
M160-08-AB	1250	355
M160-08-AC	1625	355
M160-08-BA	950	455
M160-08-BB	1250	455
M160-08-BC	1625	455

COMPONENTS

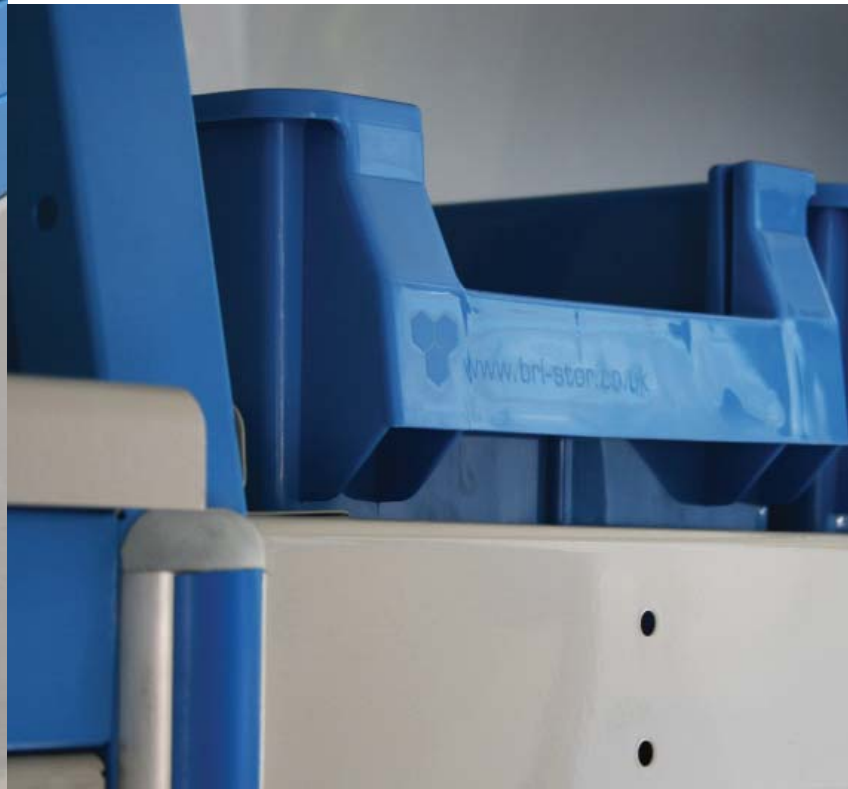

ADDITIONAL OPTIONS



Locker Housing
 (355mm depth option shown) to be located inside end panels/support angles (455mm depth option shown)

Part No	W	D	H
UCA1-400-500	500	355	400
UCA3-400-500	500	455	400

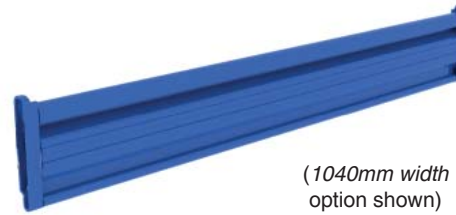

(1040mm width option shown)

Drop Down Fronts
 to be located inside shelving modules

Part No	W	H
UDD-500	500	140
UDD-750	750	140
UDD-1040	1040	140
UDD-1540	1540	140

* Please note:
 an optional back panel is available for when unit does not straddle the wheelarch



(355x1040mm option shown)

Lift Up Doors
 to be located inside end panels

Part No	W	D	H
ULD1-500	500	355	350
ULD1-750	750	355	350
ULD1-1040	1040	355	350
ULD1-1540	1540	355	350
ULD3-500	500	455	350
ULD3-750	750	455	350
ULD3-1040	1040	455	350
ULD3-1540	1540	455	350



Worktops
 (for 875mm high endpanels only)
 to be located on top of 875mm end panels
 (the 875mm are not tapered unlike other existing end panels, and so an extra 40mm is gained to the worktop)

Part No	W	D
UW1-580	580	355
UW1-830	830	355
UW1-1120	1120	355
UW1-1620	1620	355
UW3-580	580	455
UW3-830	830	455
UW3-1120	1120	455
UW3-1620	1620	455

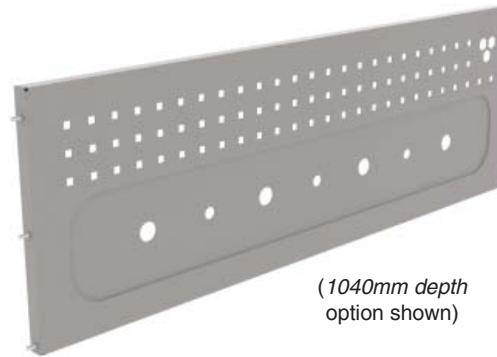

(1040mm depth option shown)

Worktops
 (for 1250mm & 1625mm high endpanels only)
 to be located inside of 1250mm or 1625mm end panels

Part No	W	D
UW1-500	500	355
UW1-750	750	355
UW1-1040	1040	355
UW1-1540	1540	355
UW3-500	500	455
UW3-750	750	455
UW3-1040	1040	455
UW3-1540	1540	455

Tool Panels
 to be located inside end panels

Part No	W	H
UTP-350-750	750	350
UTP-350-1040	1040	350
UTP-350-1540	1540	350
UTP-500-750	750	500
UTP-500-1040	1040	500
UTP-500-1540	1540	500



(322mm depth option shown)

Storage Bins
 to be located inside shelving

Part No	W	D
UMB-355	242	322
ULB-455	242	422

500mm WIDTH LOCKERS

(355mm depth options shown)



850mm High Storage Locker

Part No	H	D
M580-07-AA	850	355
M580-07-BA	850	455



1250mm High Storage Locker

Part No	H	D
M580-07-AB	1250	355
M580-07-BB	1250	455



1625mm High Storage Locker

Part No	H	D
M580-07-AC	1625	355
M580-07-BC	1625	455

STAND ALONE MODULES

(355mm depth options shown)



580mm Width Drawer/Shelf Module

Part No	H	D
M580-08-AA	950	355
M580-08-BA	950	455



* worktop option available
(please note: Height will be 900mm)



580mm Width Drawer/Shelf/Tool Case Module

Part No	H	D
M580-09-AA	950	355
M580-09-BA	950	455



* worktop option available
(please note: Height will be 900mm)

SHELVES

(355x1040mm options shown)



Plain Shelves (shelf height 70mm)
to be located mid of end panels

Part No	W	D
UPSI-460	460	355
UPSI-500	500	355
UPSI-750	750	355
UPSI-1040	1040	355
UPSI-1540	1540	355
UPS3-460	460	455
UPS3-500	500	455
UPS3-750	750	455
UPS3-1040	1040	455
UPS3-1540	1540	455



Open Shelves (shelf height 70mm)
to be located mid of end panels

Part No	W	D
UOSI-500	500	355
UOSI-750	750	355
UOSI-1040	1040	355
UOSI-1540	1540	355
UOS3-500	500	455
UOS3-750	750	455
UOS3-1040	1040	455
UOS3-1540	1540	455



Top Shelves (shelf height 70mm)
to be located ontop of end panels for 875mm modules



Part No	W	D
USS5-500	500	355
USS5-750	750	355
USS5-1040	1040	355
USS5-1540	1540	355
USS9-500	500	455
USS9-750	750	455
USS9-1040	1040	455
USS9-1540	1540	455



Tapered Top Shelves (shelf height 70mm)
to be located as the highest shelf inside of end panels



Part No	W	D
UTSI-580	580	275
UTSI-830	830	275
UTSI-1120	1120	275
UTSI-1620	1620	275
UTS3-580	580	375
UTS3-830	830	375
UTS3-1120	1120	375
UTS3-1620	1620	375



Shelf Divider Kit - (5x dividers)
to be located inside shelving

Part No	D	H
UDK1-75	355	75
UDK3-75	455	75

END PANELS



(355mm left options shown)



875mm

Left & Right Option

Part No	H	D
UPP1-875	875	355
UPP3-875	875	455



1250mm

Left Option

Part No	H	D
UTEP1-1250L	1250	355
UTEP3-1250L	1250	455

Right Option

Part No	H	D
UTEP1-1250R	1250	355
UTEP3-1250R	1250	455



1625mm

Left Option

Part No	H	D
UTEP1-1625L	1625	355
UTEP3-1625L	1625	455

Right Option

Part No	H	D
UTEP1-1625R	1625	355
UTEP3-1625R	1625	455

ANGLES, TRIM & RAIL

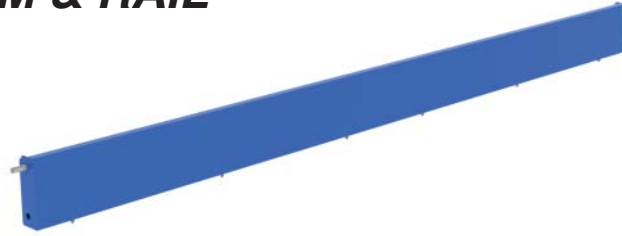

(1040mm options shown)



Floor Angle

Part No	W
UFA-500	500
UFA-750	750
UFA-1040	1040
UFA-1500	1500

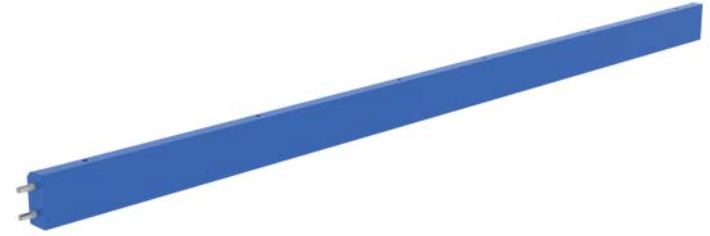

(1040mm options shown)



Bench Angle

Part No	W
UBA-500	500
UBA-750	750
UBA-1040	1040
UBA-1500	1500



400mm Support Angle

Part No	H
UCS-400	400



Trim

Part No	H
ATPA-875	875
ATPA-1250	1250
ATPA-1625	1625



(1000mm options shown)

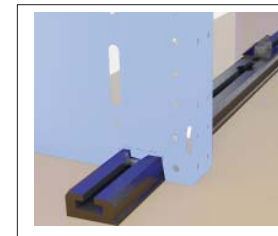

Installation Floor Rail

Part No	W
UFR-750	750
UFR-1000	1000
UFR-1250	1250
UFR-1750	1750

DRAWERS



(500mm drawer width option shown)

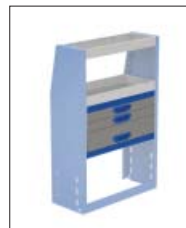

Drawer Module
to be located within a module unit

Part No	W	D
UDM1-500-2C	500	355
UDM1-750-2C	750	355
UDM3-500-2C	500	455
UDM3-750-2C	750	455



(750mm drawer width option shown)



(75mm high option shown)



Single Drawers
to be located within a drawer module

Part No	W	D	H
UD1-500-A	500	355	75
UD1-500-B	500	355	150
UD1-750-A	750	355	75
UD1-750-B	750	355	150
UD3-500-A	500	455	75
UD3-500-B	500	455	150
UD3-750-A	750	455	75
UD3-750-B	750	455	150



(150mm high option shown)



(75mm high option shown)

Drawer Divider Kit (4x dividers)
to be located inside drawers

Part No	D	H
UDDV1	355	75
UDDV3	455	75

TOOL CASES & DIVIDERS



Tool Case Brackets
to be located inside end panels/support angles

Part No	D	H
UTCR1-75	355	75
UTCR1-120	355	120
UTCR3-75	455	75
UTCR3-120	455	120



75mm Tool Case
to be located inside modules

Part No	W	D	H
UTC1-75	500	355	75



120mm Tool Case
to be located inside modules

Part No	W	D	H
UTC1-120	500	355	120



75mm Tool Case Dividers
to be located inside 75mm tool case

Part No	W	D	H
UTCD1-75	500	355	75



120mm Tool Case Dividers
to be located inside 120mm tool case

Part No	W	D	H
UTCD1-120	500	355	120

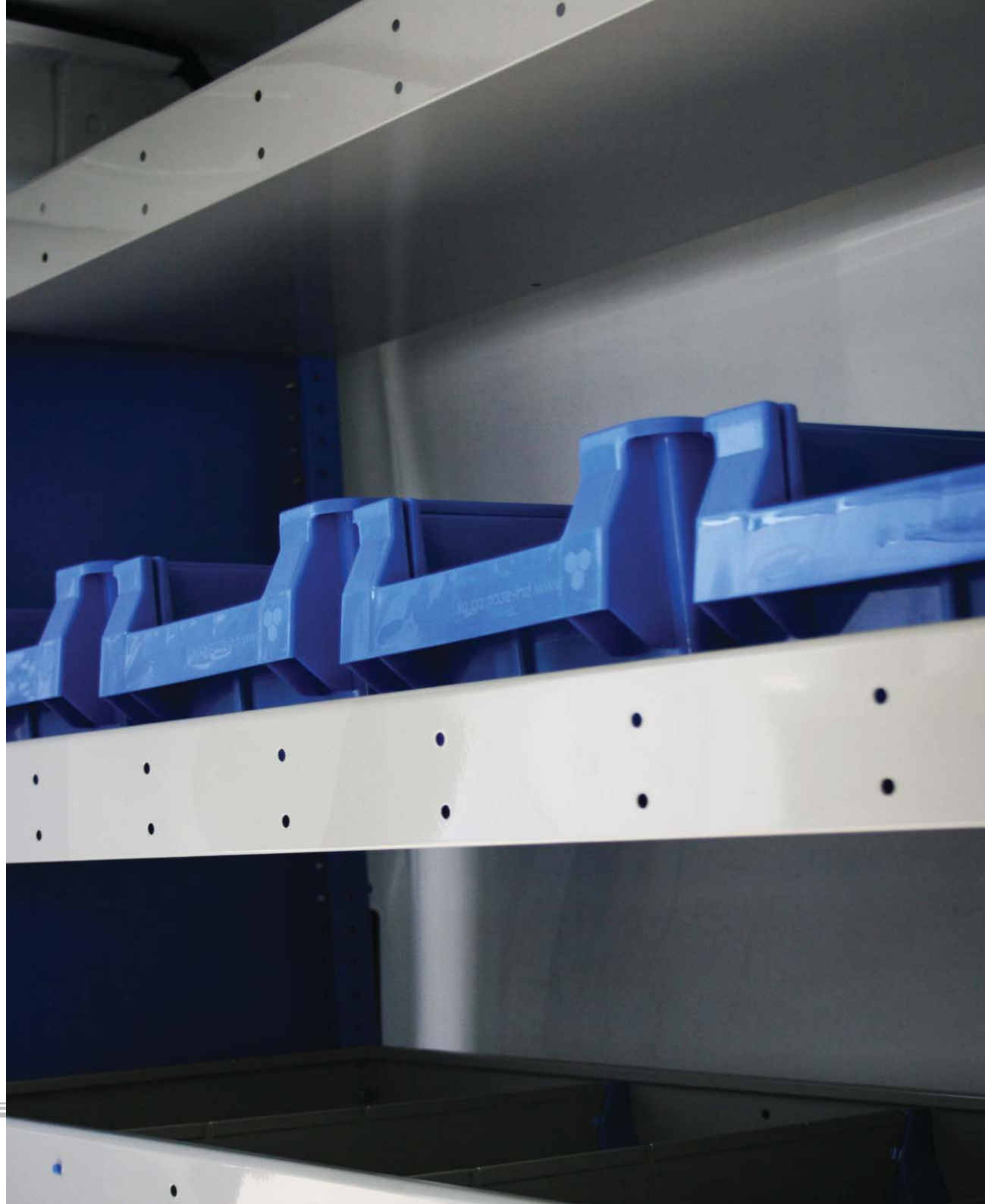



Bri-Stor Systems Limited
Church Lane, Hixon, Stafford, ST18 0PS

tel: 01889 271202
fax: 01889 271178
email: sales@bri-stor.co.uk

www.bri-stor.co.uk

